

# Determination of lifting sling lengths for UF-type stations

**GRITEC group**

Author(s):	D. Röhl, P. Gauer
Department:	TPM
Revision:	02
Date:	05.04.2024



## Determination of lifting sling lengths for UF-type stations

The maximum angle between the strands of a sling, textile or chain lifting accessories on a crane hook is determined at a maximum of  $\alpha = 25^\circ$ . This angle must always be observed so that the maximum angle,  $\beta = 12.5^\circ$ , of inclined pull from the vertical of the lifting insert is not exceeded (Fig. 2).

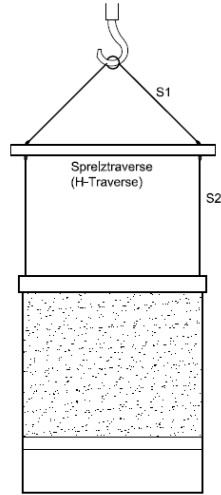

Fig. 1 H-beam

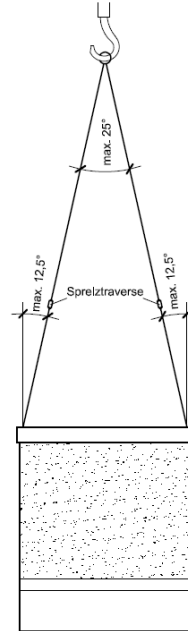

Fig. 2 Spreader beam

The transport of UF-type concrete cells without a roof or of open traps must always be carried out using an H-beam (Fig. 1) or a spreader beam (Fig. 2). This measure ensures that occurrence of transverse tensile forces directed outside the central plane of the wall is prevented. In the case of transport of concrete cells with a roof, the roof absorbs the forces from the diagonal and transverse pull.

The minimum lengths of lifting accessories for lifting concrete cells with lifting inserts located at the corners of the cell are given in Table 1. For intermediate sizes, the values for the next longer concrete cell type always apply.

Minimum sling length [m]	Series 18	Series 25	Series 27	Series 30	Series 33	Series 36	Series 42
8	1830	2530					
10	1839	2536		3030			
12	1842	2542	2742	3042	3342		4230
14		2548		3054	3348	3648	4242
16				3060	3360	3660	4254
18				3072	3372	3666	4266

Tab. 1 Lifting inserts located in the corners of the concrete cell

When selecting the length of the lifting accessories, the angle  $\alpha = 25^\circ$  (below the crane hook) must not be exceeded. If short ties are used and the size of this angle is exceeded, then an





unacceptable load is placed on the lifting inserts system and there is a risk of acute lifting insert failure.

If the required concrete cell size is not in the *Table 1* or if the lifting insert system is not located in the corners of the concrete cell, it is necessary to calculate the diagonal distance of the lifting insert according to the *Formula 1* and the related lengths of the lifting accessory strands according to the *Formula 2*.

Examples of lifting accessory lengths for different lengths of diagonal distances of the lifting inserts in relation to the structure (at  $\beta = \alpha/2 = 12.5^\circ$ ) are given in *Table 2* below.

Lifting insert diagonal in [m]	Sling length in [m]	Lifting insert diagonal in [m]	Sling length in [m]	Lifting insert diagonal in [m]	Sling length in [m]
3.50	9	6.00	14	9.00	22
4.00	10	6.50	15	9.50	22
4.50	11	7.00	16	10.00	24
5.00	12	7.50	18	10.50	26
5.50	13	8.00	20		

Tab. 2 Optional diagonal distance of lifting inserts

**Calculation of diagonal distance of lifting inserts (floor plan):**

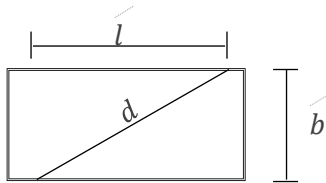

- $l$  ... Longitudinal distance of lifting inserts
- $b$  ... Transverse distance of lifting inserts
- $d$  ... Diagonal distance of lifting inserts

$$d = \sqrt{l^2 + b^2} \quad \text{(Formula 1)}$$

**Sling length calculation:**

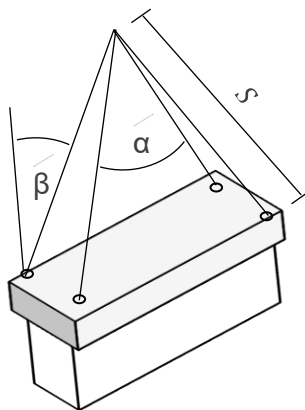
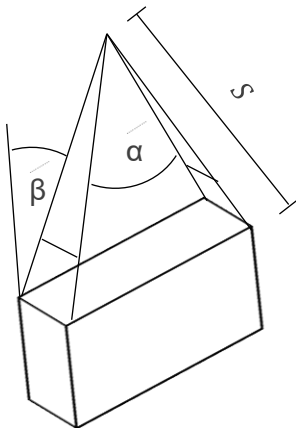

- $\alpha$  ... Angle
- $\beta$  ...  $\alpha/2 = 12.5^\circ$
- $S$  ... Length of lifting accessories
- $d$  ... Diagonal distance of lifting inserts

$$\sin \beta = \frac{\left(\frac{d}{2}\right)}{S} \rightarrow S_{\beta=12,5^\circ} = d * 2,31 \quad \text{(Formula 2)}$$

Fig. 3 Open cell with a spreader beam

Fig. 4 Cell with a roof spreader beam





For the version with a spreader beam, it is necessary to take into account that the calculated length of the **S** lifting accessory consists of two parts:

the length from the hook to the beam, and the length from the beam to the concrete body.



WE KEEP THE   
WORLD RUNNING

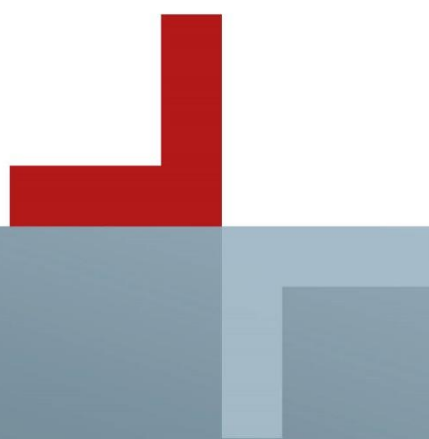

[www.gritec.com](http://www.gritec.com)